

1. Diphtongaison « romane » de [ɔ]¹ (cōr > cœur)

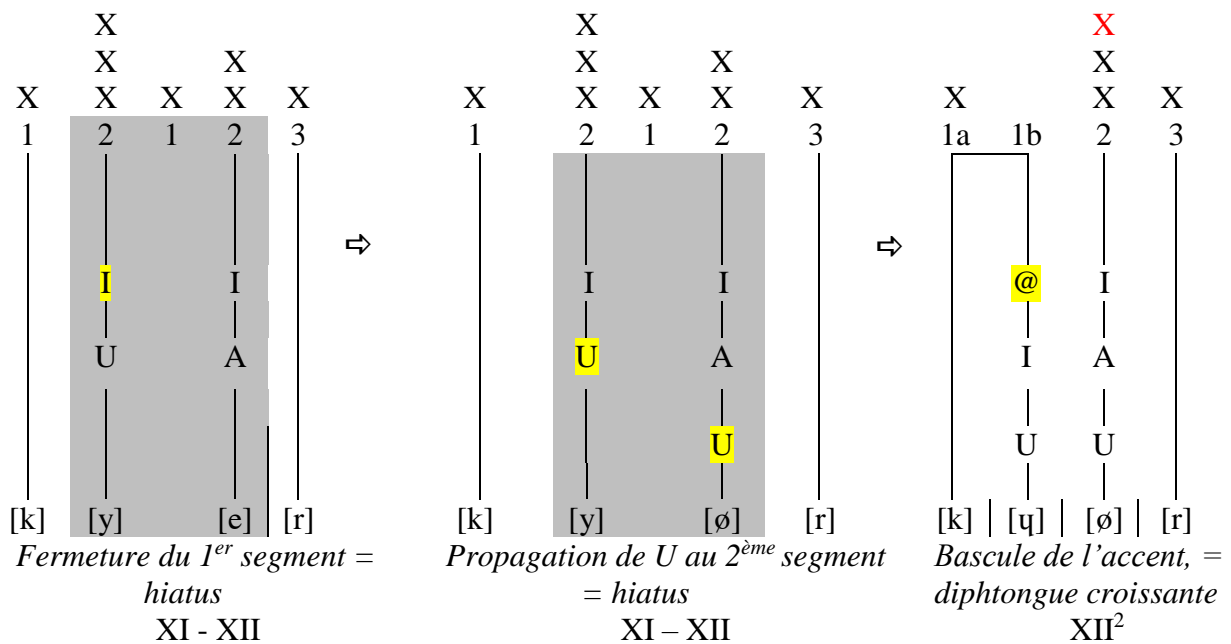

¹ Cahiers de phonétique diachronique, p. 72.

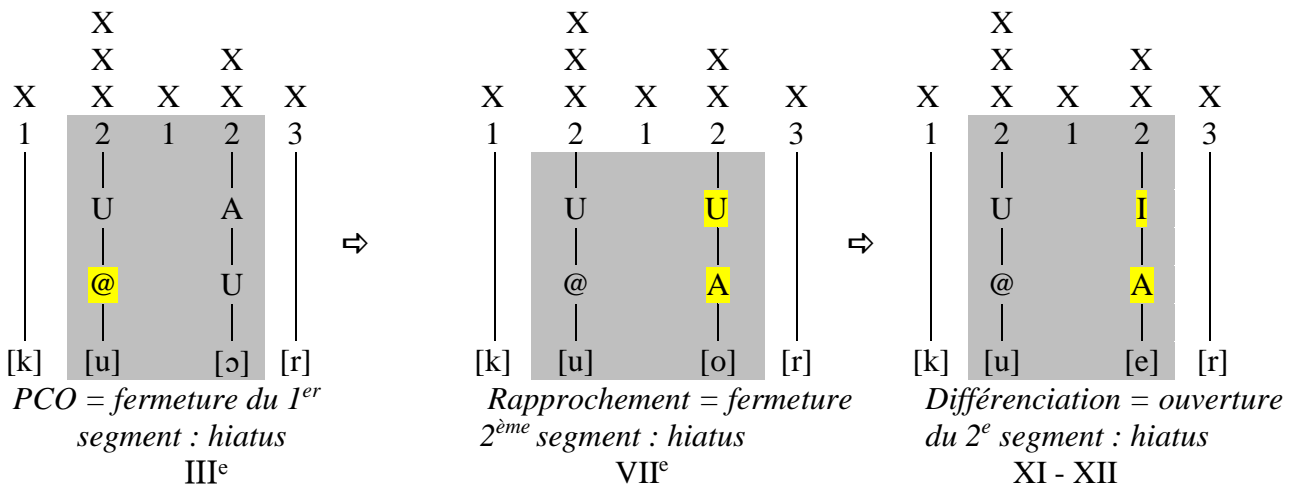
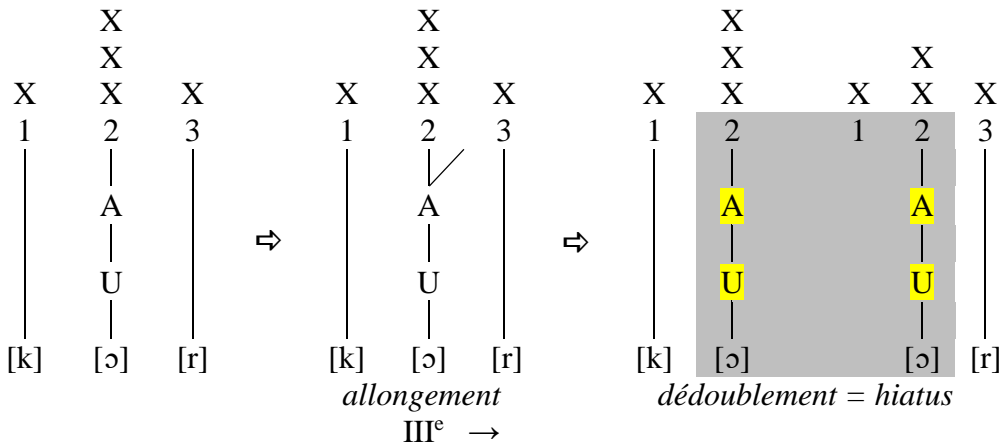
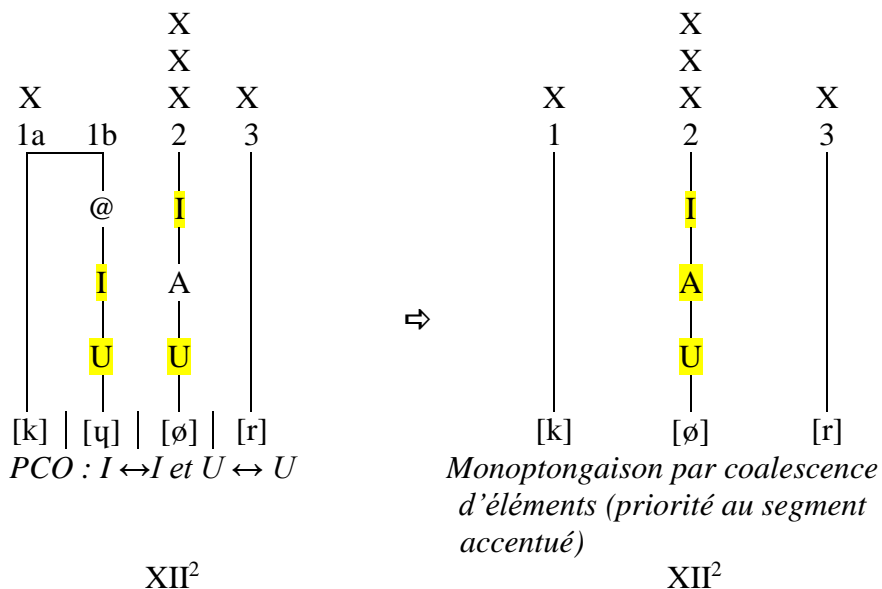

2. Diphtongaison « francienne » de [o]² (sōlu > seul)

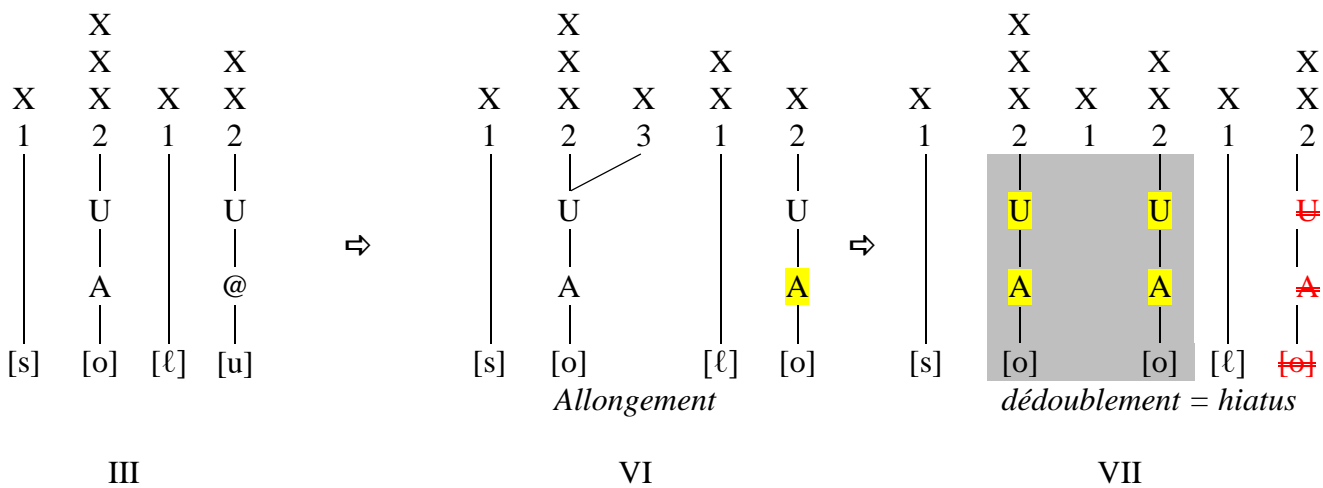

² Cahiers de phonétique diachronique, p. 72.

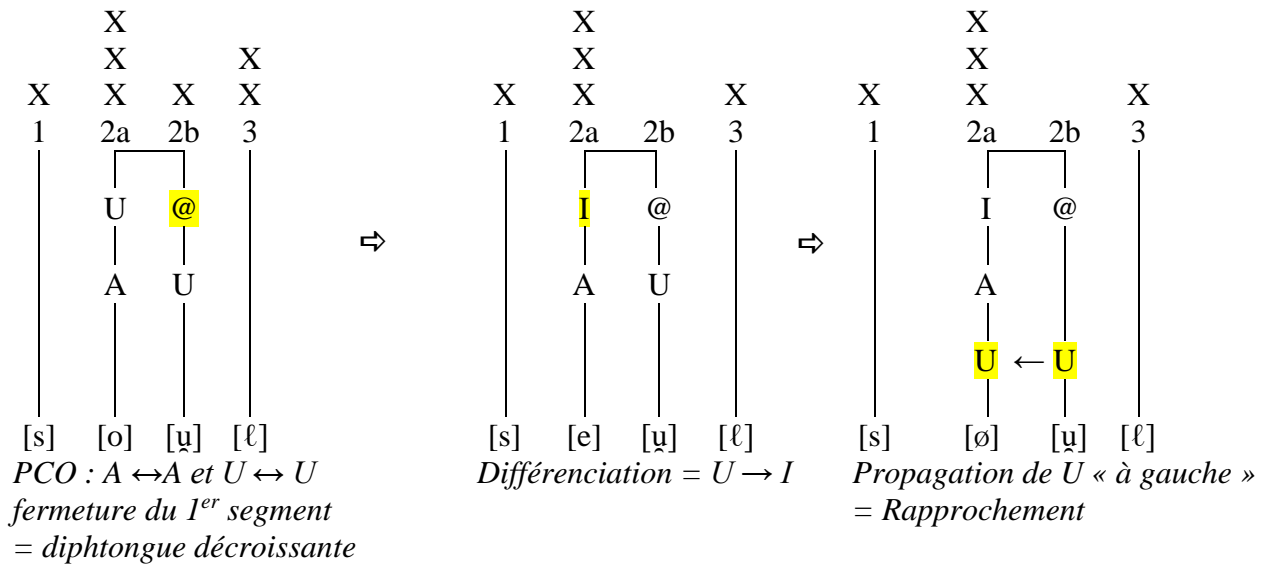

VII

VII - IX

XI

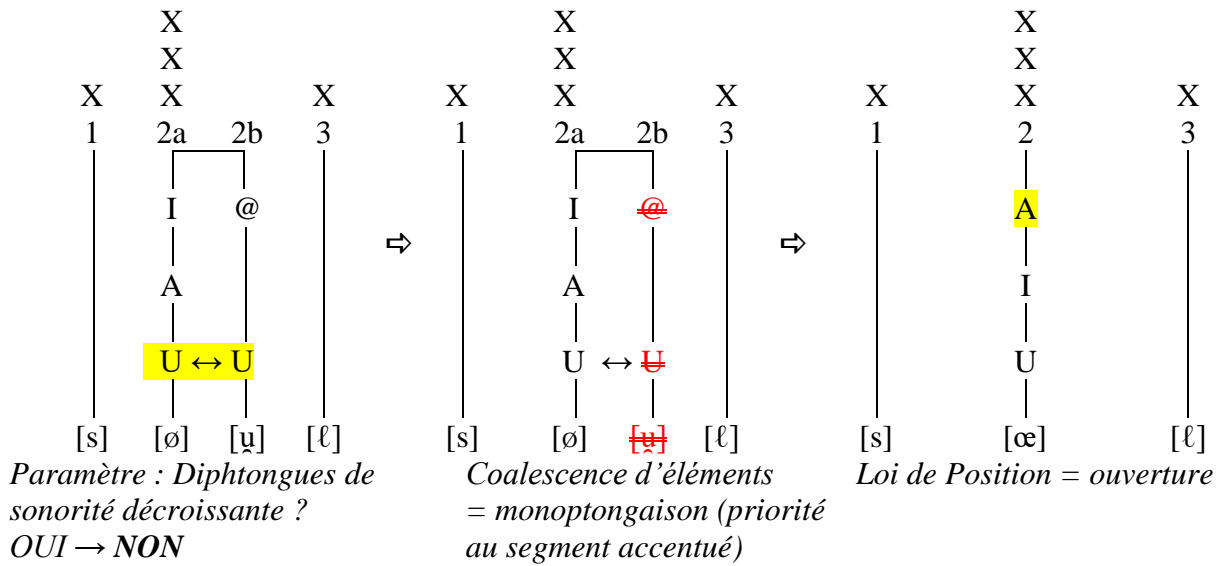

XII²

XII²

XVII - XVIII